

# Reverse Protection Relay APR-S

## Uses Voltage Detection to Determine Reverse Revolution of Three-phase Motor

- Detects motor reversal due to incorrect wiring.
- Direction of motor revolution is detected as soon as power is applied to the Relay. If the power is reversed, the magnetic contactor locks in the open state.
- The magnetic contactor can also be wired to protect it from being closed in open phase.
- Small, plug-in Relay that needs no adjustment.
- Uses voltage detection method to operate independently of load current.



APR-S (200/220 V)

APR-S380 (380/400 V)  
APR-S440 (440 V)

## Model Number Structure

### Model Number Legend

APR-S□  
1 2

1. Reverse Protection Relay

2. Control Power Supply Voltage

None: 200/220 VAC  
380: 380/400 VAC  
440: 440 VAC

## Ordering Information

### List of Models

Supply voltage	Model
200/220V	APR-S
380/400V	APR-S380
440V	APR-S440

### Connecting Sockets (Order Separately)

Applicable model	Socket		Mounting bracket
	Type	Model	Model
APR-S	Front-mounting socket	PF083A	PFC-A6
	Back-mounting socket	PL08	PLC-7
APR-S380	Front-mounting socket	P2CF-11	---
APR-S440	Back-mounting socket	PL11	Y92H-1

# Specifications

## ■ Ratings/Characteristics

Type	APR-S	APR-S380	APR-S440
Supply voltage	3-phase, 200/220 VAC, 50/60 Hz	3-phase, 380/400 VAC, 50/60 Hz	3-phase, 440 VAC, 50/60 Hz
Operating voltage range	170 to 240 VAC	350 to 420 VAC	410 to 460 VAC
Operate time	100 ms max. (from power application to detection of motor direction)		
Control output	1.1 A at 200 VAC, $\cos\phi = 1$ , SPDT 2 A at 115 VAC, $\cos\phi = 1$ 0.6 A at 200 VAC, $\cos\phi = 0.4$ 1.2 A at 115 VAC, $\cos\phi = 0.4$	1.1 A at 250 VAC, $\cos\phi = 1$ , SPDT 0.6 A at 250 VAC, $\cos\phi = 0.4$	
Insulation resistance	100 M $\Omega$ min. (at 500 VDC)		
Dielectric strength	2,000 VAC, 50/60 Hz for 1 min		
Shock	Malfunction: 98 m/s <sup>2</sup> (approx. 10 G)		
Ambient temperature	-10 to 50 °C		
Life expectancy	Mechanical: 1,000,000 operations min. Electrical: 100,000 operations min.		
Weight	Approx. 100 g		

## Connections

### To Detect Reverse Phase or Open Phase

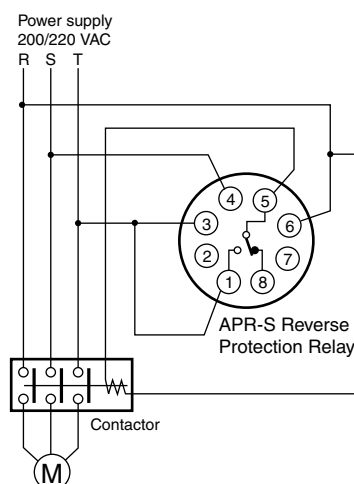

### Operation

- Suppose the motor revolves in the forward direction when the input terminals ⑥, ④, and ③ of the APR-S are connected, in this sequence, to the power lines. The APR-S Relay turns ON when the phase sequence of the voltage is in the forward direction, that is, when the power lines R, S, and T are energized in this sequence. When the Relay turns ON, terminals ⑤ and ① conduct, energizing the contactor. If one of the three phases is reversed, the Relay does not turn ON and the contactor is not energized.
- To protect the motor from damage due to open phase, the wiring must be performed in exactly the same way as shown in this figure (i.e., so that the phase connecting the contactor coil is not the same as the phase connecting terminal ④ of the Relay). If phase R or T is open, the contactor does not operate because one side of its coil is not energized. If phase S (connected to terminal ④ of the Relay) opens, the Relay does not turn ON, allowing no current flow between terminals ⑤ and ①. The contactor therefore does not operate.

Note, however, that the contactor is prevented from operating by preventing an open-phase voltage from flowing into the motor and not by the open-phase protection feature of the Relay.

**Note:** Open-phase detection is only possible when a 200/220-VAC APR-S is used with the wiring exactly the same as shown in the above diagram.

### To Switch to Reverse Phase

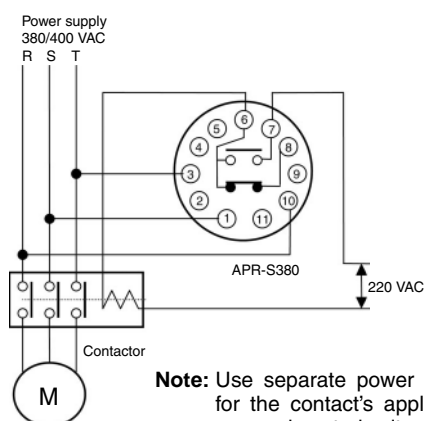

**Note:** Use separate power supplies for the contact's applied voltage and control voltage.

### Operation

- Suppose the motor revolves in the forward direction when the input terminals ⑩, ①, and ③ of the APR-S are connected, in this sequence, to the power lines R, S, and T, respectively. The APR-S Relay turns ON when the phase sequence of the current is in the forward direction, that is, when the power lines R, S, and T are energized in this sequence. When the Relay turns ON, terminals ⑥ and ⑦ conduct, energizing the contactor. If one of the three phases is reversed, the Relay does not turn ON, and terminals ⑥ and ⑦ do not conduct, but a current flows between terminals ⑥ and ⑧, energizing the reverse-phase contactor.

**Note:** Open-phase detection is not possible.

# Accessories (Order Separately)

## ■ Dimensions

APR-S

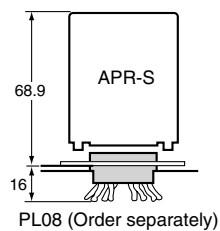
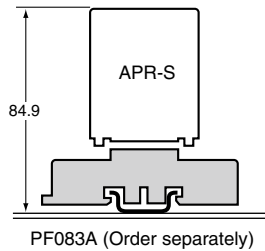
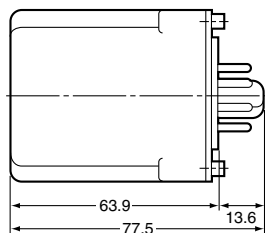
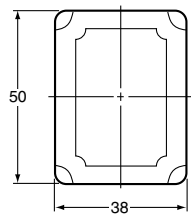

APR-S380/S440

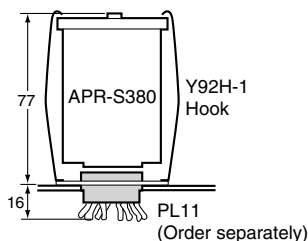
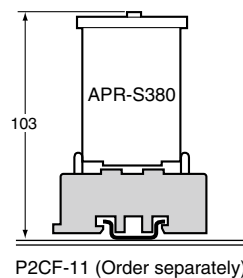
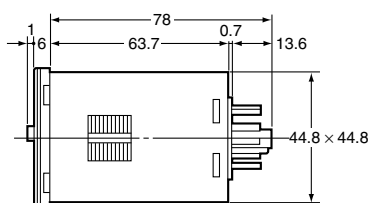
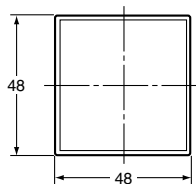

## ■ Terminal Arrangement

APR-S

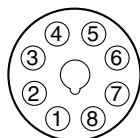

(Bottom View)

APR-S380/S440

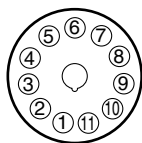

(Bottom View)

# Accessories for Track Mounting

## PFP-100N/PFP-50N Socket Mounting Track

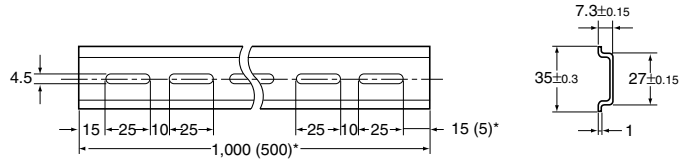
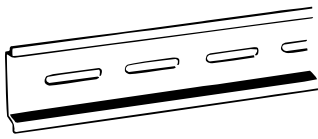

\* The dimensions given in parentheses are for the PFP-50N Socket Mounting Track.

## PFP-100N2 Socket Mounting Track

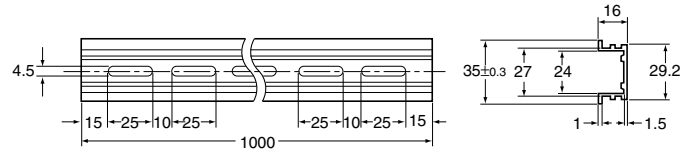
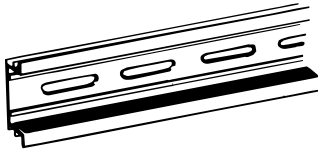

## PFP-M End Plate

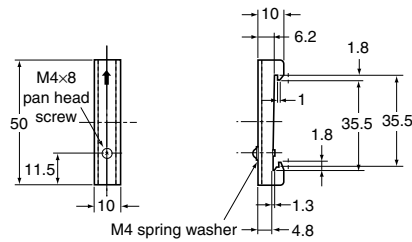
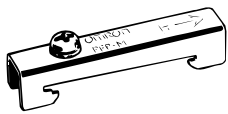

## Spacer

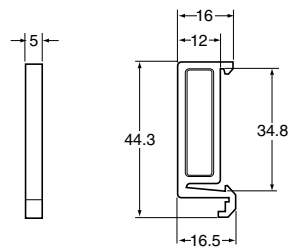
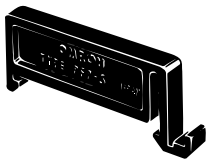

# Safety Precautions

## Correct Use

- With the 200/220-VAC APR-S, an open phase at startup can be prevented only if connections are external and wiring has been performed to detect reverse phase and open phase at startup when the power supply is turned ON. When doing so, use an SE Static Motor Relay. An open phase when the power supply is turned ON can be detected only when it occurs between the APR-S and the power supply. An open phase cannot be detected on the load side.
- Suppose the motor revolves in the forward direction when the input terminals 6, 4, and 3 of the APR-S are connected, in this sequence, to the power lines. If the phase sequence of the power supply applied to the APR-S is a positive sequence (i.e., applying to R to S to T in the order of 6 to 4 to 3), the relay built into the APR-S will turn ON, there will be continuity between terminals 5 and 1, and the contactor will be energized. For reverse phase, the built-in relay will not turn ON and the contactor will not be energized.
- An open phase when the power is turned ON can be prevented when wiring is performed exactly as in the following figure (when wiring is performed so that the phase of the connected contactor coil for turning ON the power supply and the phase of the connected terminal 4 of the APR-S are not the same phase).

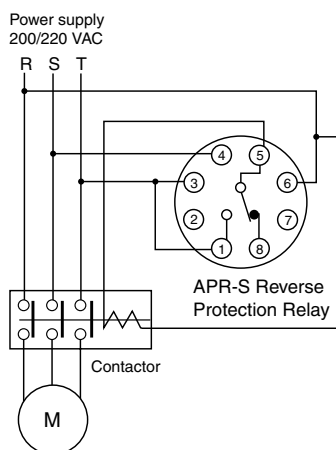

In the figure above, one side of the contactor coil will not be energized if either phase R or phase T is open phase, so the power supply will not turn ON. For open R phase (APR-S terminal 4), the built-in relay of the APR-S will not turn ON, and there will be no conductivity between terminals 5 and 1, so the contactor will not operate, and the power supply will not turn ON. **This protection is for an open phase when the power is turned ON and cannot ensure detection of an open phase when the motor is operating.**

- Incorrect wiring on the magnet contactor load side cannot be detected.
- A phase detection method is used, so usage is not possible with single phase.

## Mounting

- If a back-mounting socket is used for mounting, mount the socket flush from the back of the panel (thickness: 1 to 4 mm) using screws, and insert the APR-S after the socket is sufficiently tightened. Make sure the socket is mounted with the key slot downward.
- If a front-mounting socket is used, mount the socket to the panel using screws, and insert the APR-S after the socket is sufficiently tightened.
- Use a mounting bracket to secure the APR-S reliably and prevent contact faults.

ALL DIMENSIONS SHOWN ARE IN MILLIMETERS.

To convert millimeters into inches, multiply by 0.03937. To convert grams into ounces, multiply by 0.03527.

In the interest of product improvement, specifications are subject to change without notice.

## Switching to Reverse Phase

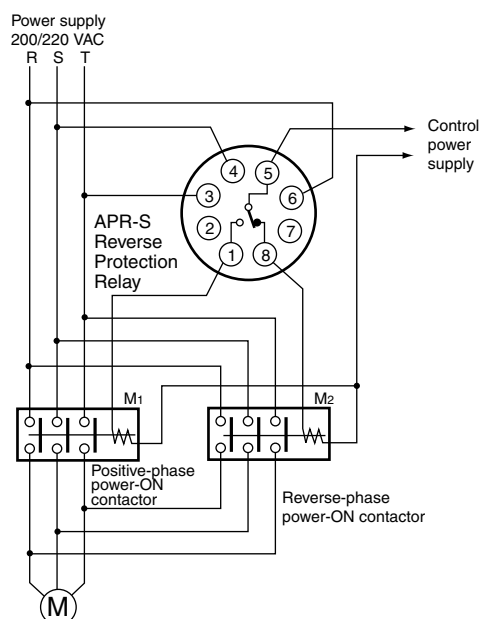

- Suppose the motor revolves in the forward direction when the input terminals 6, 4, and 3 of the APR-S are connected, in this sequence, to the power lines, R, S, and T, respectively. If the phase sequence of the power supply applied is the positive sequence, the relay built into the APR-S will turn ON, there will be continuity between terminals 5 and 1, and the positive-phase power-ON contactor will be energized. For reverse phase, the built-in relay will not turn ON, there will be conductivity between terminals 5 to 8, and the reverse-phase power-ON contactor will be energized. In this way, the voltage supplied to the motor will remain positive phase whether the voltage applied is positive phase or reverse phase.

### Note

The APR-S requires 100 ms after the voltage has been applied until positive phase and reverse phase are detected. Be sure to allow at least 100 ms to elapse before applying voltage to the control power supply after applying voltage to the APR-S.

## Read and Understand This Catalog

Please read and understand this catalog before purchasing the products. Please consult your OMRON representative if you have any questions or comments.

## Warranty and Limitations of Liability

### WARRANTY

OMRON's exclusive warranty is that the products are free from defects in materials and workmanship for a period of one year (or other period if specified) from date of sale by OMRON.

OMRON MAKES NO WARRANTY OR REPRESENTATION, EXPRESS OR IMPLIED, REGARDING NON-INFRINGEMENT, MERCHANTABILITY, OR FITNESS FOR PARTICULAR PURPOSE OF THE PRODUCTS. ANY BUYER OR USER ACKNOWLEDGES THAT THE BUYER OR USER ALONE HAS DETERMINED THAT THE PRODUCTS WILL SUITABLY MEET THE REQUIREMENTS OF THEIR INTENDED USE. OMRON DISCLAIMS ALL OTHER WARRANTIES, EXPRESS OR IMPLIED.

### LIMITATIONS OF LIABILITY

OMRON SHALL NOT BE RESPONSIBLE FOR SPECIAL, INDIRECT, OR CONSEQUENTIAL DAMAGES, LOSS OF PROFITS, OR COMMERCIAL LOSS IN ANY WAY CONNECTED WITH THE PRODUCTS, WHETHER SUCH CLAIM IS BASED ON CONTRACT, WARRANTY, NEGLIGENCE, OR STRICT LIABILITY.

In no event shall responsibility of OMRON for any act exceed the individual price of the product on which liability is asserted.

IN NO EVENT SHALL OMRON BE RESPONSIBLE FOR WARRANTY, REPAIR, OR OTHER CLAIMS REGARDING THE PRODUCTS UNLESS OMRON'S ANALYSIS CONFIRMS THAT THE PRODUCTS WERE PROPERLY HANDLED, STORED, INSTALLED, AND MAINTAINED AND NOT SUBJECT TO CONTAMINATION, ABUSE, MISUSE, OR INAPPROPRIATE MODIFICATION OR REPAIR.

## Application Considerations

### SUITABILITY FOR USE

OMRON shall not be responsible for conformity with any standards, codes, or regulations that apply to the combination of products in the customer's application or use of the product.

At the customer's request, OMRON will provide applicable third party certification documents identifying ratings and limitations of use that apply to the products. This information by itself is not sufficient for a complete determination of the suitability of the products in combination with the end product, machine, system, or other application or use.

The following are some examples of applications for which particular attention must be given. This is not intended to be an exhaustive list of all possible uses of the products, nor is it intended to imply that the uses listed may be suitable for the products:

- Outdoor use, uses involving potential chemical contamination or electrical interference, or conditions or uses not described in this catalog.
- Nuclear energy control systems, combustion systems, railroad systems, aviation systems, medical equipment, amusement machines, vehicles, safety equipment, and installations subject to separate industry or government regulations.
- Systems, machines, and equipment that could present a risk to life or property.

Please know and observe all prohibitions of use applicable to the products.

NEVER USE THE PRODUCTS FOR AN APPLICATION INVOLVING SERIOUS RISK TO LIFE OR PROPERTY WITHOUT ENSURING THAT THE SYSTEM AS A WHOLE HAS BEEN DESIGNED TO ADDRESS THE RISKS, AND THAT THE OMRON PRODUCT IS PROPERLY RATED AND INSTALLED FOR THE INTENDED USE WITHIN THE OVERALL EQUIPMENT OR SYSTEM.

## Disclaimers

### CHANGE IN SPECIFICATIONS

Product specifications and accessories may be changed at any time based on improvements and other reasons.

It is our practice to change model numbers when published ratings or features are changed, or when significant construction changes are made. However, some specifications of the product may be changed without any notice. When in doubt, special model numbers may be assigned to fix or establish key specifications for your application on your request. Please consult with your OMRON representative at any time to confirm actual specifications of purchased product.

### DIMENSIONS AND WEIGHTS

Dimensions and weights are nominal and are not to be used for manufacturing purposes, even when tolerances are shown.

### ERRORS AND OMISSIONS

The information in this catalog has been carefully checked and is believed to be accurate; however, no responsibility is assumed for clerical, typographical, or proofreading errors, or omissions.

### PERFORMANCE DATA

Performance data given in this catalog is provided as a guide for the user in determining suitability and does not constitute a warranty. It may represent the result of OMRON's test conditions, and the users must correlate it to actual application requirements. Actual performance is subject to the OMRON Warranty and Limitations of Liability.

### PROGRAMMABLE PRODUCTS

OMRON shall not be responsible for the user's programming of a programmable product, or any consequence thereof.

### COPYRIGHT AND COPY PERMISSION

This catalog shall not be copied for sales or promotions without permission.

This catalog is protected by copyright and is intended solely for use in conjunction with the product. Please notify us before copying or reproducing this catalog in any manner, for any other purpose. If copying or transmitting this catalog to another, please copy or transmit it in its entirety.